

Typical Elevation
Scale 1:40

2 Sided Vertical Structural Glazed
Curtain Walling System

See full size details shown on
Assembly drawings of Mullions & Transoms
in section 4 of this manual

* : For typical Firestop details at floor slab
see manual pages 4/20, 4/21, 4/49, 4/50,
4/51, 4/52, 4/58, and 4/59.

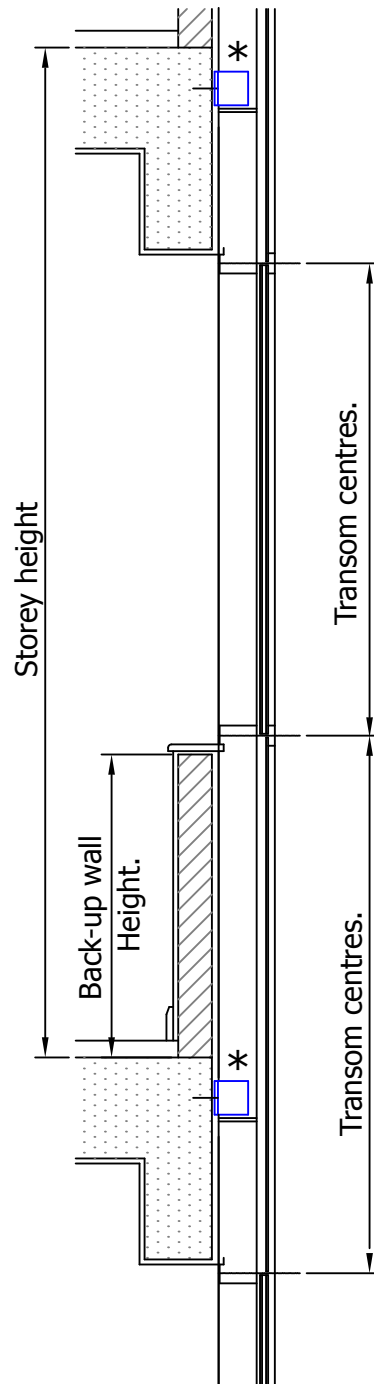

Typical Vertical Section
Scale 1:20

