

NTB-55-DOOR

Door open-in and out door systems (non-thermally broken)

The system is glazed internally to accommodate 24mm or 26mm double glazed units, using standard beads. As with all Brital systems, the Door system is manufactured to exacting standards enabling economy to be combined with strength to give many years of aesthetic, trouble-free operation.

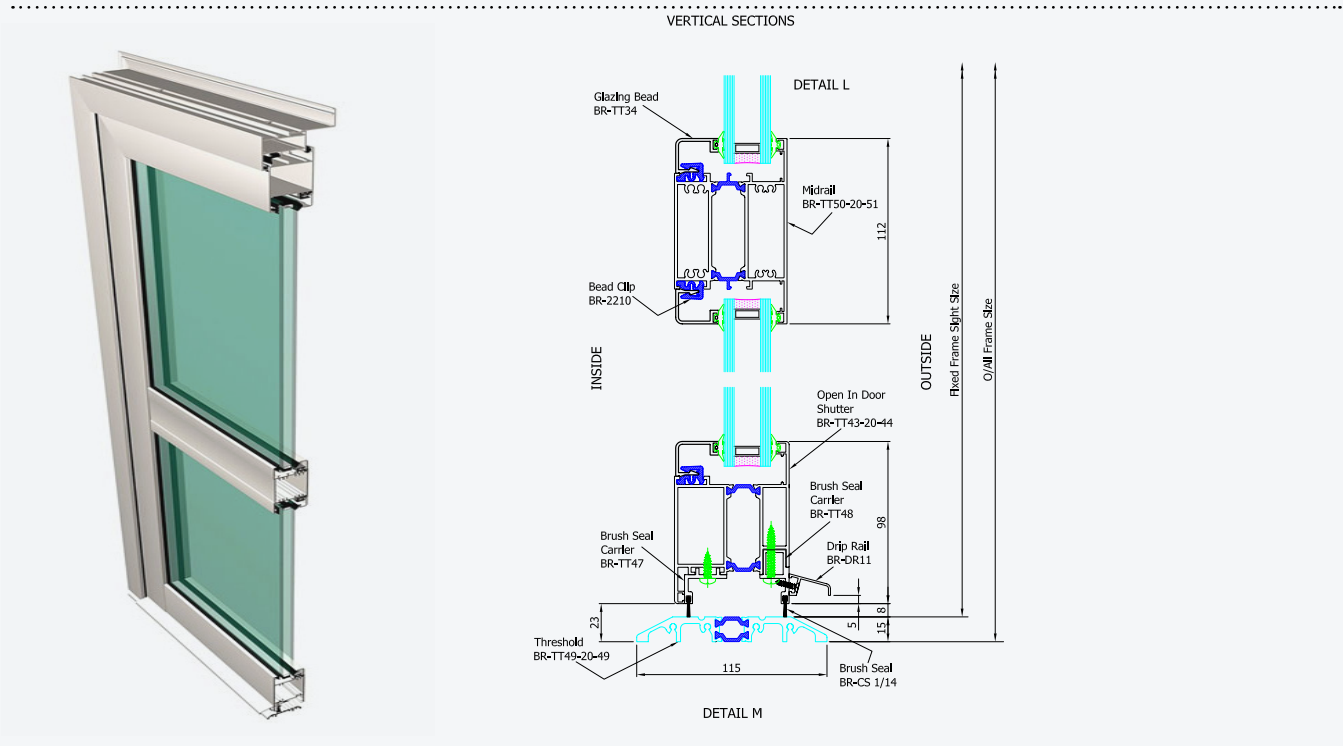

NTB-55-DOOR System Performance



SIZE

- Door shutter weights Medium Duty door with BR-8020 Hinge - 150kg (max)
- Bacony Door with two BR-9211.6 hinges - 80kg (max) with three BR-9211.6 hinges - 90kg (max) with two BR-8041.1 hinges - 90kg (max)



DESIGN

- Corners formed as 45 degree mitres to provide a quality appearance, high performance and weather resistance.
- All frame joints are fully sealed during manufacture.
- Opening panels fully weather-sealed with woolpile seals.



PERFORMANCE

- Economy is combined with strength to provide many years of trouble free operation and to be aesthetically pleasing.
- The Brital thermally broken system should be used where additional thermal performance is required



INSTALLATION

- Detailed installation instructions are provided on our web site

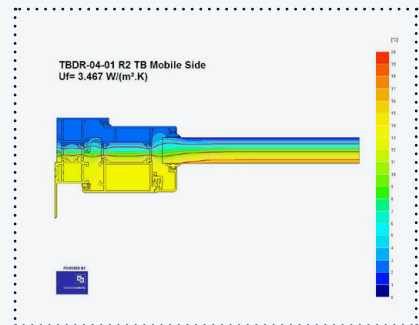

Isotherm Diagram

DISCOVER MORE ON OUR WEBSITE

