

CG-4-56

4 Sided Fully Capped Curtain Walling System

The system currently offers frames for three types of glazed units, a 24mm thick double glazed fixed light unit, a 6mm single glazed spandrel panel and a 24mm double glazed top hung casement. Fixed double glazing incorporates flush edged double glazing units, whilst the top hung windows utilise double glazing units that have stepped edges to enable clean and continuous sight lines whilst providing high levels of performance. All fixed double glazed units MUST be dual sealed with a P.I.B. primary seal and a secondary seal.

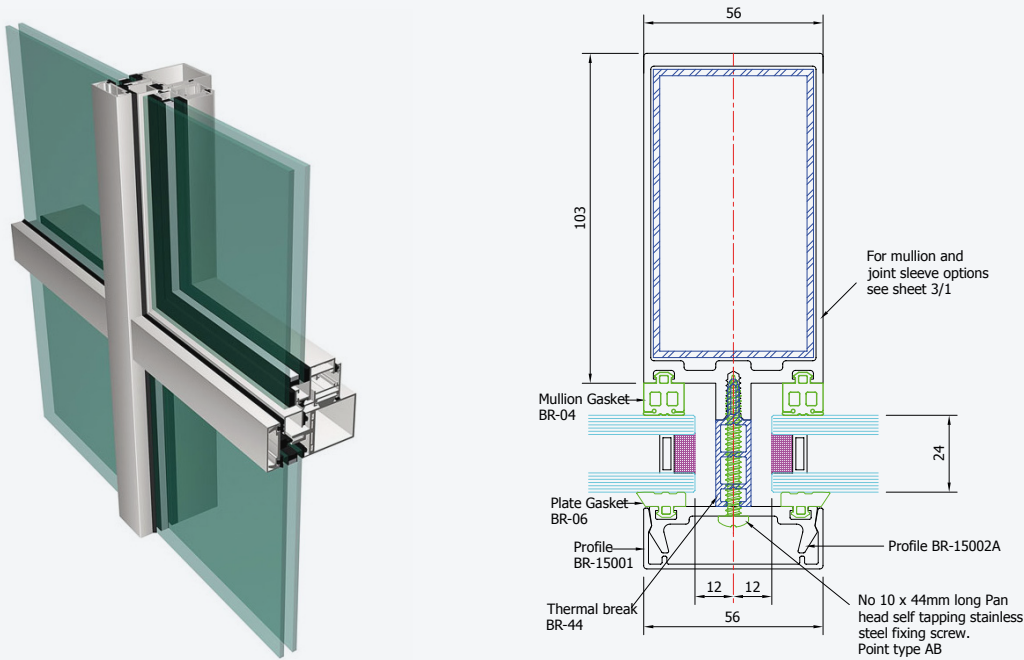

CG-4-56

System Performance



SIZE

- Profile width only 56mm.
- Profile depths from 43mm to 200mm.



DESIGN

- Designed specifically for the Gulf climatic conditions.
- Designed to perform at windloads in excess of 2.4 kPa.
- Designed to meet the CWCT standards so meets BS:EN, ASTM, AAMA specifications.



PERFORMANCE

- Neat extruded vertical cover caps conceal glazing fixings.
- Thermal Break frameless outward opening vent panels can be incorporated as can framed open-in vents.
- Thermal performance can achieve U_{cw} of 1.6 W/m²/K.



INSTALLATION

- Single or double glazed spandrel panels, aluminium composite cladding panels can all be incorporated into the system.

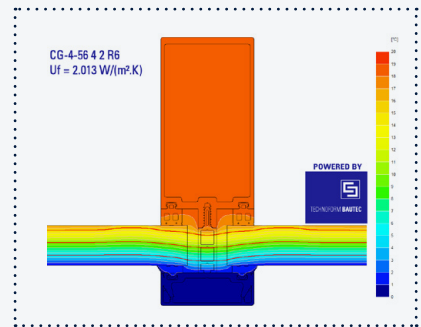

Isotherm Diagram

DISCOVER
MORE ON OUR
WEBSITE

